

ASTRO-TECH AT80ED

from Astronomy Technologies

Thank you for choosing this **Astro-Tech AT80ED** high-quality apochromatic refractor.

While some observers might doubt that apochromatic performance can be had in an 80mm scope that costs as little as the AT80ED, we can say only that seeing is believing.

The images from its 550mm f/6.9 ED (Extra-low Dispersion glass element) air-spaced doublet optics are virtually color-free, even at high magnifications. At its low price, we believe

you'll find that the optical performance of your AT80ED is little short of astonishing.

This instruction manual will provide you with information on how to get the most out of your new telescope, and how to properly maintain your telescope so it can give you a lifetime of observing enjoyment.

Please familiarize yourself with your telescope's parts and functions before operating it for the first time.

PARTS OF THE AT80ED

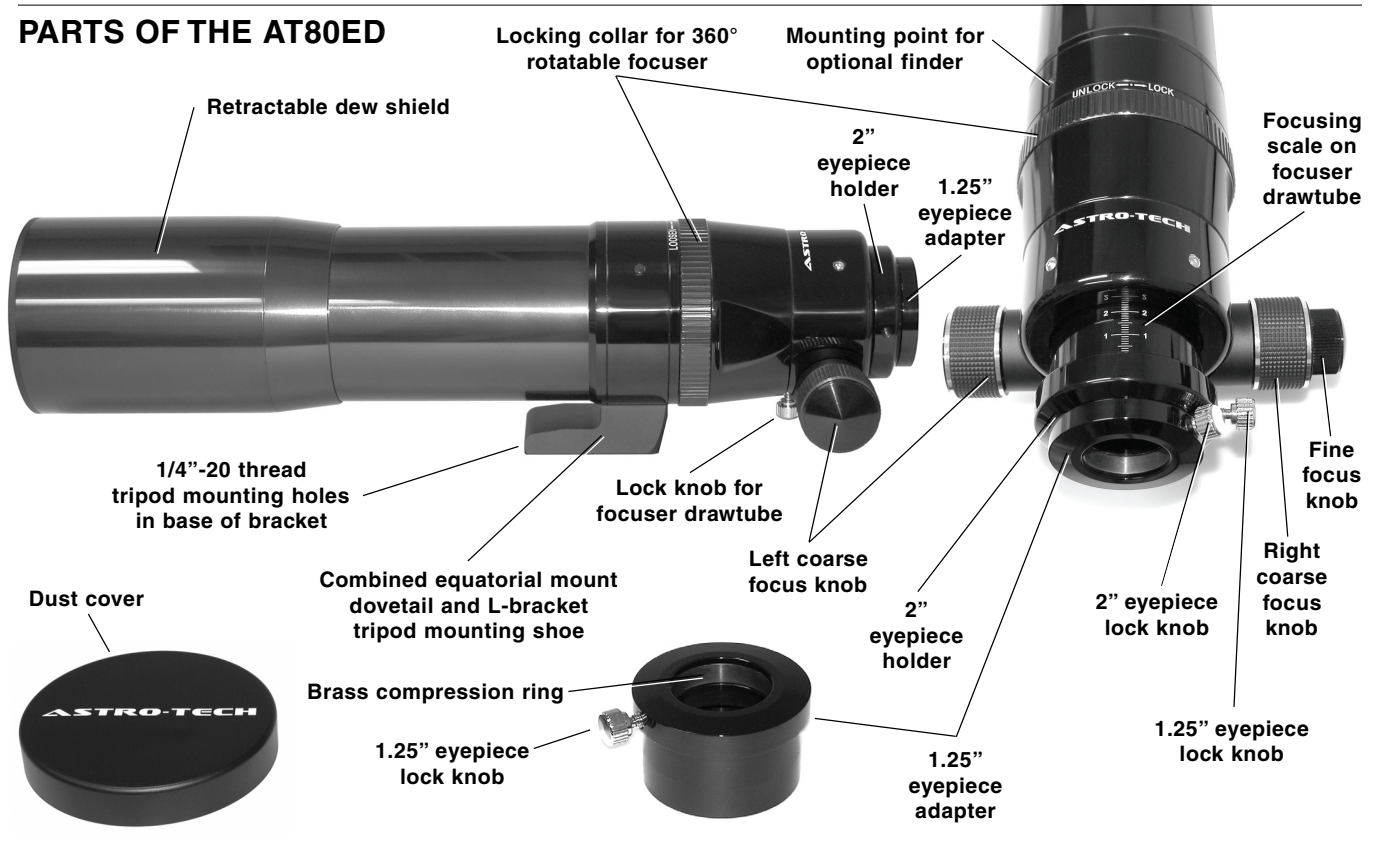

Astro-Tech AT80ED Apochromatic Refractor Specifications

Aperture 80mm (3.1")
Focal Length 550mm
Focal Ratio f/6.9
Objective Type air-spaced doublet with ED element
Optical Coatings fully multicoated
Resolving Power (Dawes' Limit) 1.45 arc seconds
Visual Limiting Magnitude 12.0 maximum
Light Grasp (versus the eye) 131x
Field Stops 10 glare-reducing baffles in optical tube
Focuser dual-speed Crayford-type
with 11:1 reduction ratio fine focus;
360° rotating camera angle/observing angle adjuster;
and 2" and 1.25" compression ring eyepiece holders
Focuser Travel 3.1" (80mm)
with millimeter scale on drawtube for repeatable focus
Lens Shade retractable

Objective Lens Cover slip-on metal
Tripod Mount ... removable combination L-bracket and
dovetail with 1/4"-20 thread mounting holes for photo
tripod use as well as direct mounting on Celestron,
Meade, and Vixen German equatorial mounts
Tube Diameter 90mm o. d.
Tube Length (lens shade retracted) 18" (457mm)
Tube Length (lens shade extended)... 20.75" (527mm)
Optical Tube Weight 6.55 lbs. (3 kg)
Case aluminum-frame foam-fitted
lockable hard case, with carrying handle
Case Dimensions 22.25" x 12.5" x 7.5"
Lowest Usable Power 13.75x (40mm eyepiece)
Highest Terrestrial Power 78x (7mm eyepiece)
Highest Practical Power 137x (4mm eyepiece)
Theoretical Maximum 183x (3mm eyepiece)

Your **Astro-Tech AT80ED** refractor is usable for day and night viewing, simply by adding a star diagonal and eyepiece. Any brand of eyepiece can be used, from a 40mm for the lowest practical magnification (13.75x), to a 3mm (183x) for high power use. A 2" eyepiece holder on the focuser drawtube and a supplied 1.25" eyepiece adapter let you use either 1.25" or 2" star diagonals and eyepieces with no other adapter needed.

The focal length of the AT80ED is ideal for low to medium power wide-angle views of nebulas, open star clusters, large galaxies, and comets. Crisp views of the Moon and planets are also routine at magnifications of 110x to 183x when seeing conditions permit.

To calculate the magnification of your telescope and eyepiece combination, divide the telescope focal length in mm by the eyepiece focal length in mm. For example, a 5mm eyepiece in the AT80ED will give you a magnification of 110x (550mm/5mm = 110).

Astronomical Observing: The theoretical maximum usable power available from this telescope is 183x, although this requires a 3mm eyepiece that provides a narrow and very dim 0.44mm exit pupil. A more practical maximum magnification for astronomical viewing with the AT80ED would be 137x, using a 4mm eyepiece. Keep in mind that seeing conditions play an important role in how high a magnification you can use on any given night. Only very good seeing conditions (clear skies and calm air) will support viewing at 183x. Under less than ideal conditions, lower powers in the 78x to 110x range provide more consistently usable and pleasing images.

The widest possible field of view with a 1.25" eyepiece is about 3°, which can be achieved with a 13.75x (40mm) Plössl eyepiece.

While the AT80ED has not been specifically designed for astrophotography, it does an outstanding job as a wide-field astrograph for casual 35mm and CCD imaging. A chrome thumbscrew under the focuser lets you lock in a sharp focus for photography.

The focuser can be rotated a full 360° for the best photographic composition, or to put your diagonal in the most comfortable observing position. To rotate the focuser, loosen the knurled lock ring on the telescope barrel by turning it counterclockwise. Adjust the focuser to the desired angle, then turn the lock ring back in the opposite direction to lock the focuser at the new angle.

Terrestrial Observing: The AT80ED works well for daytime birding, nature studies, sweeping the landscape from the home with a view, etc. It is also a very good 550mm (11x) f/6.9 telephoto lens for terrestrial photography. Generally speaking, the maximum usable daytime power with any terrestrial scope is about 1x per mm of aperture (78x with the AT80ED). Attempts to push the daytime power beyond this point often magnify the heat waves, dust, and "mirage" in our atmosphere to the point where the images become blurry and unusable. A 22x (25mm) to 69x (8mm) eyepiece is usually more satisfying for everyday high power terrestrial use than a 78x eyepiece.

Mounting the AT80ED: A stable tripod or astronomical mount is essential for best viewing. The AT80ED is light enough to be used on any good quality camera tripod with an 8 to 10 pound payload capacity, using either of the two 1/4"-20 thread holes in the scope's L-shaped mounting bracket. The front mounting hole provides a better balance when the scope is used with a 1.25" star diagonal and eyepiece. The rear mounting hole provides a better balance when the scope is used with a heavier 2" diagonal and eyepiece, or a camera.

The L-bracket is shaped like the dovetail used to connect optical tubes to the Celestron CG-5 Advanced Series, Meade LX-D75, and Vixen Sphinx and Great Polaris German equatorial mounts. This dovetail shape allows you to install the AT80ED directly on any of these mounts with no other adapter required.

The L-bracket can be removed from the AT80ED by undoing the recessed hex-head bolts holding it to the scope body. This allows you to mount the scope on an accessory dovetail plate by using a pair of optional Astro-Tech 90mm split mounting rings.

Optional Astro-Tech Accessories: Astro-Tech makes 1.25" and 2" star diagonals with state-of-the-art 99% reflectivity dielectric coatings that nicely complement the performance of the AT80ED. These diagonals are available from your Astro-Tech dealer to provide

the maximum possible reflectivity and planetary detail. An Astro-Tech 45° viewing angle image-erecting 1.25" diagonal is available for terrestrial observing. An inexpensive Astro-Tech illuminated non-magnifying multi-reticle finder is also available for your AT80ED.

Caring for Your Scope Optics: Never store the telescope in a damp or humid environment. Avoid leaving it in a hot environment (exposed to direct sunlight on a window sill, in a car trunk, etc.) If you must store it in high humidity conditions, put a few packets of desiccant (silica gel or the equivalent, available from most camera stores) in with the telescope to absorb excess moisture. If not properly stored in a humid environment, the telescope may develop mildew which can damage the optics.

If dew has formed on the scope after a night of observing, allow the scope optics to air dry at room temperature before putting the lens cover on the scope and storing it away.

If the front lens surface becomes dusty, smeared, or shows fingerprints or any other surface build-up, clean the lens as follows. First, gently blow away any surface dust or particles with a clean air blower (a child's ear syringe or a photographer's camel's hair brush with attached blower bulb, for example). Using canned or compressed air is not recommended, as the propellant in the can may spit out and leave difficult-to-remove deposits on the lens. Also, the expanding compressed air drops in temperature as it leaves the can. The cold air coming out of the tiny tube that most compressed air cans use to direct the air flow has been known to chill a lens to the point of cracking the glass if pointed at the same spot on the glass for too long.

Second, moisten a cloth with a few drops of a photographic-quality optical cleaning solution designed for multicoated camera and binocular lenses. A well-worn cotton handkerchief works well and Zeiss and Kodak both make suitable fluids. Do not drip the cleaning fluid directly on the lens. Use the barely damp (not wet) cloth to gently wipe the lens surface clean, turning the cloth frequently to always keep a clean portion of the cloth in contact with the lens. Blot the lens dry with a dry portion of the cleaning cloth or a separate cloth. Start with a clean cloth each time cleaning is needed.

Avoid overcleaning your scope. The multicoatings on the lens are quite hard and durable. However, frequent overzealous cleaning can scratch the coatings if all the dust particles (which are often tiny flecks of windborne rock) are not removed before you start pushing a damp cloth around the lens surface. A few specks of debris on the lens will not be visible in your images, as they are not in the focal plane and don't block enough light to measure, let alone be seen. Clean your optics only when absolutely necessary. If you take proper care of your scope, cleaning should rarely be needed.

Caring for Your Scope Finish: The AT80ED uses a high gloss liquid-anodize finish. The very durable anodized surface can become smudged with fingerprints during use, but these will not harm the finish. A clean soft cloth slightly dampened with plain water (or a little moisture from your breath and a quick wipe with a clean handkerchief) is generally enough to remove the fingerprints. Avoid harsh chemical cleaners or organic solvents like benzene, alcohol, etc., as these may ruin the finish. They can certainly affect the optical coatings if they accidentally drip or splash on the objective lens.

Never use the telescope in the rain or in conditions where it may get wet. The telescope is not waterproof. If the telescope accidentally gets caught in the rain, immediately wipe off all water using a clean and dry soft cloth. If the telescope gets totally soaked in water, or submerged, immediately contact your dealer for service instructions. Do not disassemble or attempt to repair your telescope yourself, as this violates the warranty terms under the limited product warranty, and negates any guarantee.

Caution! Never directly view the Sun with your telescope! Never aim your AT80ED at the Sun without having a professionally-manufactured solar filter mounted over the objective lens. Viewing the Sun through the scope without the proper protection for even a moment may result in permanent severe damage to your eyes, and can even cause blindness. Contact your Astro-Tech dealer if you are interested in purchasing a compatible professional solar filter.

 **ASTRO-TECH** www.astronomytechnologies.com
from Astronomy Technologies, PO Box 720013, Norman, OK 73070